

UNITED STATES DEPARTMENT OF THE INTERIOR
NATIONAL PARK SERVICE

FOR NPS USE ONLY

RECEIVED

DATE ENTERED

NATIONAL REGISTER OF HISTORIC PLACES
INVENTORY -- NOMINATION FORM

SEE INSTRUCTIONS IN HOW TO COMPLETE NATIONAL REGISTER FORMS
TYPE ALL ENTRIES -- COMPLETE APPLICABLE SECTIONS

1 NAME

HISTORIC

7. SIMPSON CREEK COVERED BRIDGE (ALIAS W.T. LAW COVERED BRIDGE)

AND/OR COMMON

2 LOCATION

STREET & NUMBER Secondary Route 24/2 at junction of Secondary Route 24
at Holen Mill across Simpson Creek

NOT FOR PUBLICATION

CITY, TOWN

CONGRESSIONAL DISTRICT

X VICINITY OF Bridgeport

1

STATE

West Virginia

CODE
54

COUNTY
Harrison

CODE
033

3 CLASSIFICATION

CATEGORY	OWNERSHIP	STATUS	PRESENT USE
<input type="checkbox"/> DISTRICT	<input checked="" type="checkbox"/> PUBLIC	<input checked="" type="checkbox"/> OCCUPIED in service	<input type="checkbox"/> AGRICULTURE <input type="checkbox"/> MUSEUM
<input type="checkbox"/> BUILDING(S)	<input type="checkbox"/> PRIVATE	<input type="checkbox"/> UNOCCUPIED	<input type="checkbox"/> COMMERCIAL <input type="checkbox"/> PARK
<input checked="" type="checkbox"/> STRUCTURE	<input type="checkbox"/> BOTH	<input type="checkbox"/> WORK IN PROGRESS	<input type="checkbox"/> EDUCATIONAL <input type="checkbox"/> PRIVATE RESIDENCE
<input type="checkbox"/> SITE	<input type="checkbox"/> PUBLIC ACQUISITION	<input type="checkbox"/> ACCESSIBLE	<input type="checkbox"/> ENTERTAINMENT <input type="checkbox"/> RELIGIOUS
<input type="checkbox"/> OBJECT	<input type="checkbox"/> IN PROCESS	<input type="checkbox"/> YES: RESTRICTED	<input type="checkbox"/> GOVERNMENT <input type="checkbox"/> SCIENTIFIC
	<input type="checkbox"/> BEING CONSIDERED	<input checked="" type="checkbox"/> YES: UNRESTRICTED	<input type="checkbox"/> INDUSTRIAL <input checked="" type="checkbox"/> TRANSPORTATION
		<input type="checkbox"/> NO	<input type="checkbox"/> MILITARY <input type="checkbox"/> OTHER:

4 OWNER OF PROPERTY

NAME

West Virginia Department of Highways

STREET & NUMBER

1900 Washington Street, East

CITY, TOWN

Charleston

VICINITY OF

STATE

West Virginia 25305

5 LOCATION OF LEGAL DESCRIPTION

COURTHOUSE,
REGISTRY OF DEEDS, ETC.

Harrison County Court House

STREET & NUMBER

CITY, TOWN

Clarksburg

STATE

West Virginia

6 REPRESENTATION IN EXISTING SURVEYS

TITLE

None

DATE

FEDERAL STATE COUNTY LOCAL

DEPOSITORY FOR
SURVEY RECORDS

CITY, TOWN

STATE

2 DESCRIPTION

CONDITION		CHECK ONE	CHECK ONE
<input type="checkbox"/> EXCELLENT	<input type="checkbox"/> DETERIORATED	<input checked="" type="checkbox"/> UNALTERED	<input type="checkbox"/> ORIGINAL SITE
<input checked="" type="checkbox"/> GOOD	<input type="checkbox"/> RUINS	<input type="checkbox"/> ALTERED	<input checked="" type="checkbox"/> MOVED DATE 1888
<input type="checkbox"/> FAIR	<input type="checkbox"/> UNEXPOSED		

DESCRIBE THE PRESENT AND ORIGINAL (IF KNOWN) PHYSICAL APPEARANCE

The W. T. Law Covered Bridge is 14 feet-3 inches wide and is 75.2 feet in length. It has red board-and-batten siding and a corrugated metal roof. The trusses which are of the multiple kingpost type, have nine panels, measuring 11.9 feet in height. All panels are approximately 8 feet-4 inches long. The 7 x 8 inch diagonals fit flush against the top and bottom chords, which are comprised of two-6 x 8 inch and two-6 x 9½ inch members respectively, and into small three sided notches made in the 7 x 10 inch verticals. The center panel of the bridge has no diagonal bracing, which was a common mode of design for timber bridges of the multiple kingpost type that had an odd number of panels (1). Because the center panel is unbraced, it must resist loading through the bending of the cords, relying on their continuity (i.e. the top and bottom chords are continuous and therefore do not act as members of a pin-connected truss) for stability. The joggle splice pieces, which splice the components of the bottom chord together are noteworthy.

The bridge still functions with no evidence of modern reinforcement.

8 SIGNI
PERIO
-PR

SIGNIFICANCE

PERIOD	AREAS OF SIGNIFICANCE -- CHECK AND JUSTIFY BELOW			
<input type="checkbox"/> PREHISTORIC	<input type="checkbox"/> ARCHEOLOGY-PREHISTORIC	<input type="checkbox"/> COMMUNITY PLANNING	<input type="checkbox"/> LANDSCAPE ARCHITECTURE	<input type="checkbox"/> RELIGION
<input type="checkbox"/> 1400-1499	<input type="checkbox"/> ARCHEOLOGY-HISTORIC	<input type="checkbox"/> CONSERVATION	<input type="checkbox"/> LAW	<input type="checkbox"/> SCIENCE
<input type="checkbox"/> 1500-1599	<input type="checkbox"/> AGRICULTURE	<input type="checkbox"/> ECONOMICS	<input type="checkbox"/> LITERATURE	<input type="checkbox"/> SCULPTURE
<input type="checkbox"/> 1600-1699	<input type="checkbox"/> ARCHITECTURE	<input type="checkbox"/> EDUCATION	<input type="checkbox"/> MILITARY	<input type="checkbox"/> SOCIAL/HUMANITARIAN
<input type="checkbox"/> 1700-1799	<input type="checkbox"/> ART	<input checked="" type="checkbox"/> ENGINEERING	<input type="checkbox"/> MUSIC	<input type="checkbox"/> THEATER
<input checked="" type="checkbox"/> 1800-1899	<input type="checkbox"/> COMMERCE	<input type="checkbox"/> EXPLORATION/SETTLEMENT	<input type="checkbox"/> PHILOSOPHY	<input checked="" type="checkbox"/> TRANSPORTATION
<input type="checkbox"/> 1900-	<input type="checkbox"/> COMMUNICATIONS	<input type="checkbox"/> INDUSTRY	<input type="checkbox"/> POLITICS/GOVERNMENT	<input type="checkbox"/> OTHER (SPECIFY)
		<input type="checkbox"/> INVENTION		

SPECIFIC DATES 1881 BUILDER/ARCHITECT Asa S. Hugill

STATEMENT OF SIGNIFICANCE

Thomas S. Spates, appointed by the Harrison County Court as a commissioner to examine a site, prepare specifications, and receive bids for the construction of a bridge across Simpson Creek near Shinns Mills, made a report to the court on September 9, 1881 concerning his progress. After he informed the court that Asa S. Hugill submitted the lowest bid, (\$700.00 for the woodwork and \$4.00/perch for the wingwalls and abutments), the court awarded Mr. Hugill the contract. The same day, the court appointed Thomas S. Spates to superintend the construction of the bridge, and ordered that John Lowe be awarded \$40.00 for land taken for right-of-way.

On December 6, 1881, following Spates' report to the court that Hugill had built the bridge according to the plans and specifications, the court ordered that Hugill be paid a total of \$1483.00, \$442.00 of which was to be given to John Lowe. Spates was paid \$30.00 for his services as a commissioner (2).

A flood washed out the bridge in July, 1999. The bridge was brought back upstream and reconstructed at its present location, which is approximately one-half mile below its original site.

The W. T. Law Covered Bridge is one of the three remaining covered bridges in Harrison County, and the only covered bridge in West Virginia that has multiple kingpost trusses with diagonals absent in the center panels. As a rule of thumb, wooden arches were constructed on bridges which were to have spans approaching 80 feet to avoid excessive deflections. The W. T. Law bridge is significant in that it comes close to the 80 foot span length and does not have stiffening wooden arches.

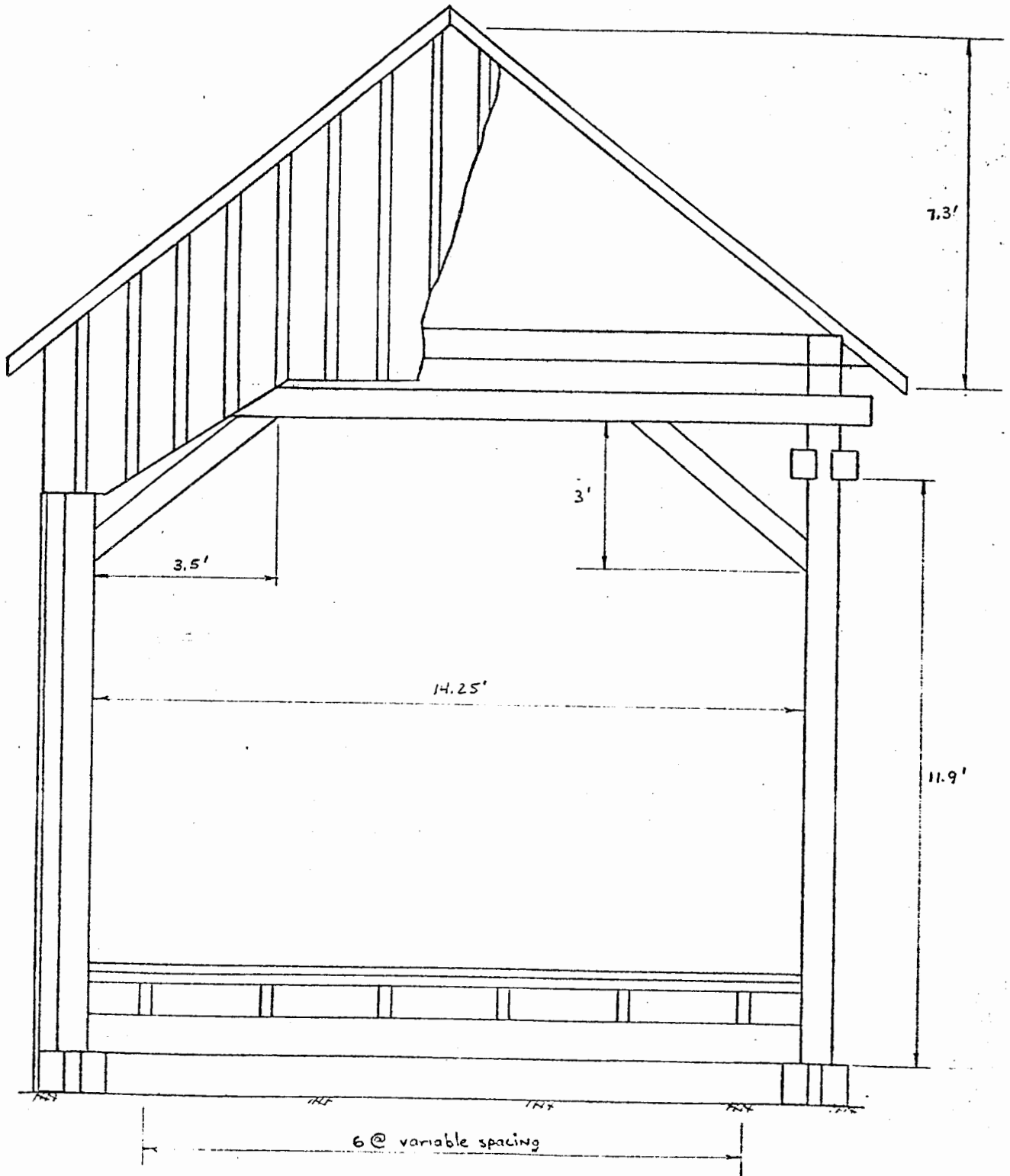

8. SIMPSON CREEK COVERED BRIDGE

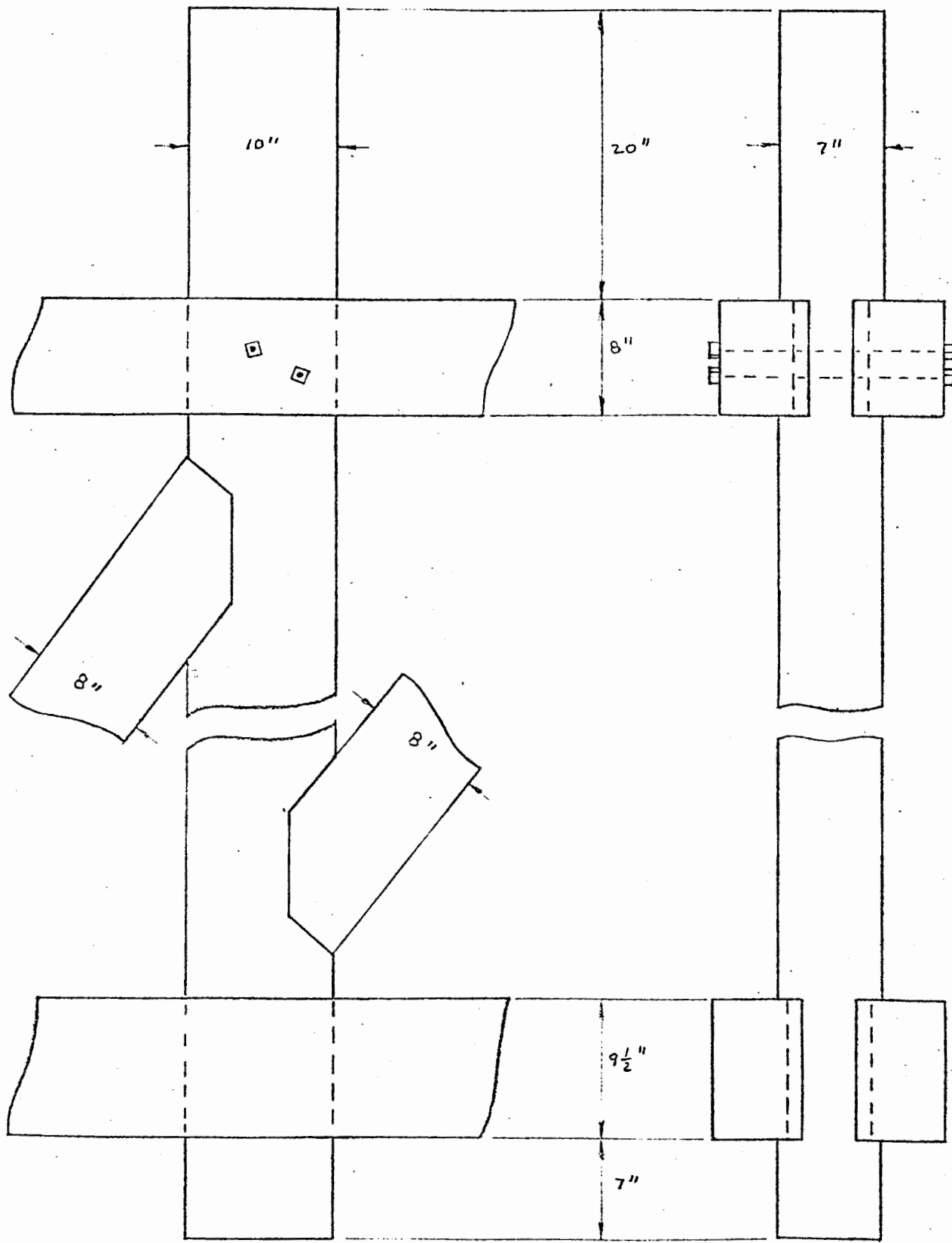

8. SIMPSON CREEK COVERED BRIDGE

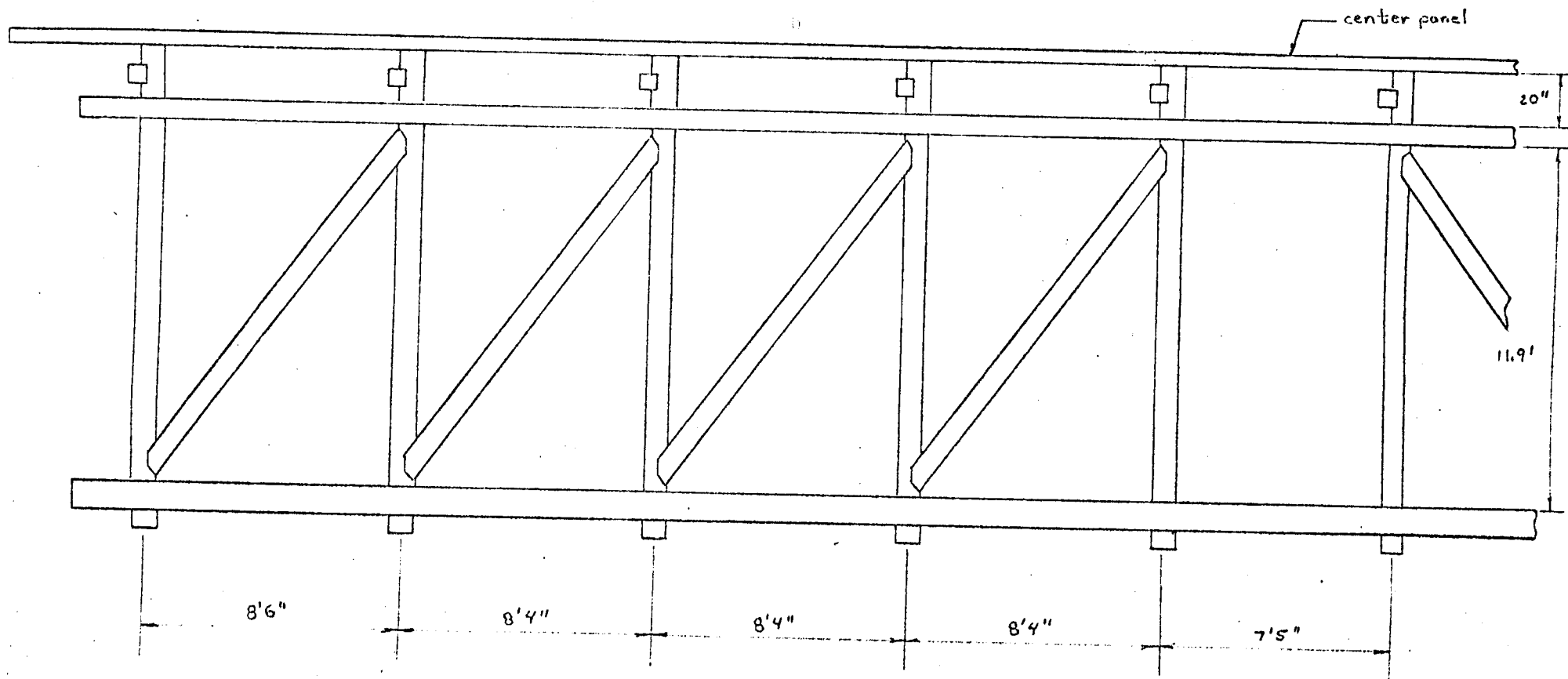

8. SIMPSON CREEK COVERED BRIDGE

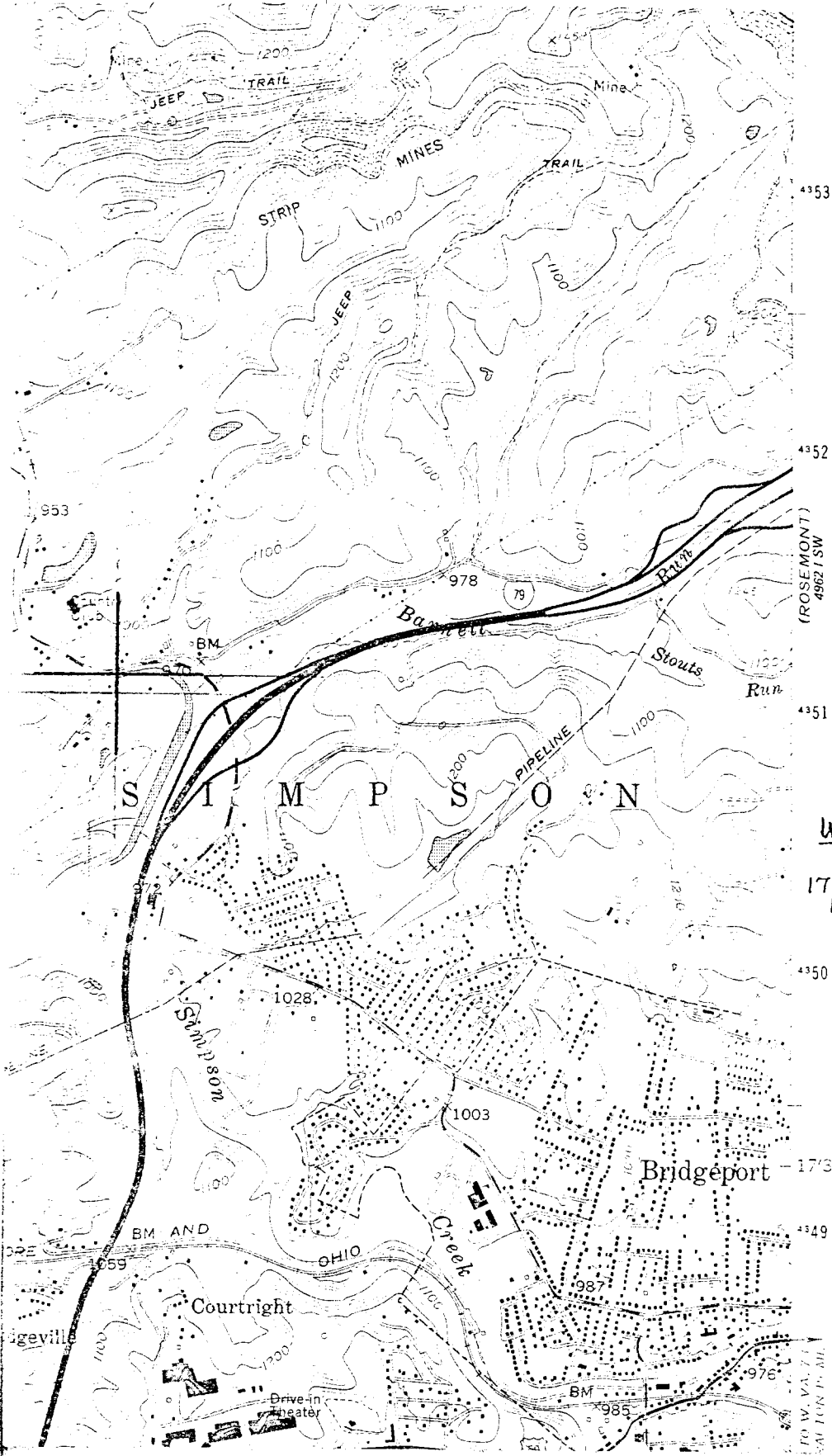

7.
 SIMPSON CREEK
 COVERED BRIDGE
 BRIDGEPORT
 VICINITY
 HARRISON COUNTY
 WEST VIRGINIA

UTM
 17 | 562 100 | 4351 068

